



## TOROID MOUNTS

- Seven vertical mounts catalogued
- Custom Design Service
- Through hole termination options
- Horizontal types under development
- Available in high performance polymers





# Toroid Mounts

## TOROID MOUNT TR0010

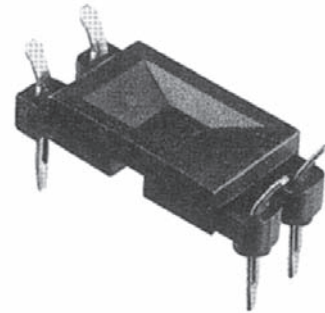
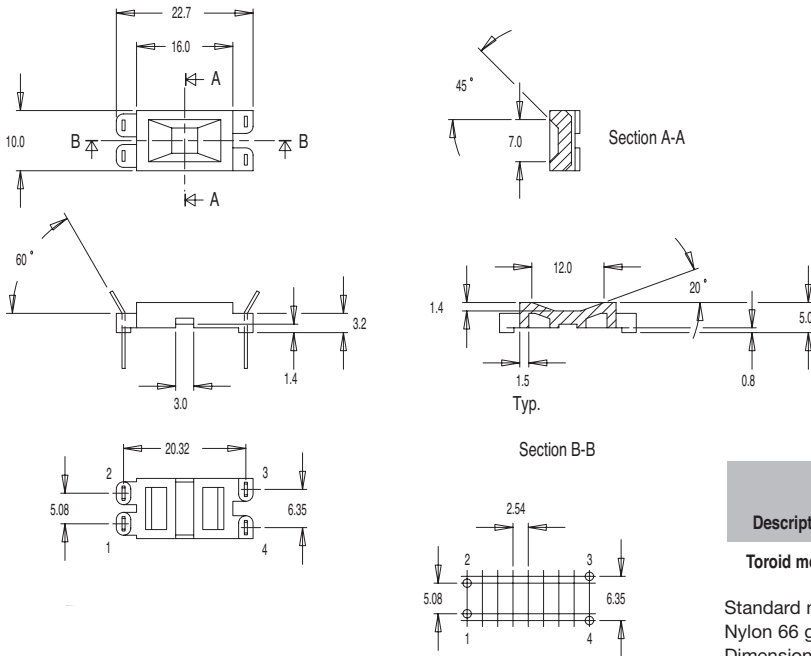

Description	Type	Terminal type	No. of terminals available	Part No.
Toroid mount	72958	TBS 901	4 (2 x 2)	TR0010

Standard materials: Nylon 66 glass reinforced to UL94HB / Nylon 66 glass reinforced to UL94V0  
Dimensions in millimetres

## TOROID MOUNT TR0020

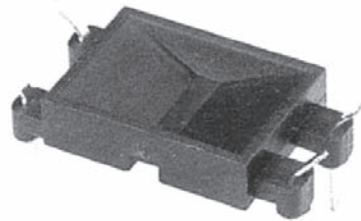
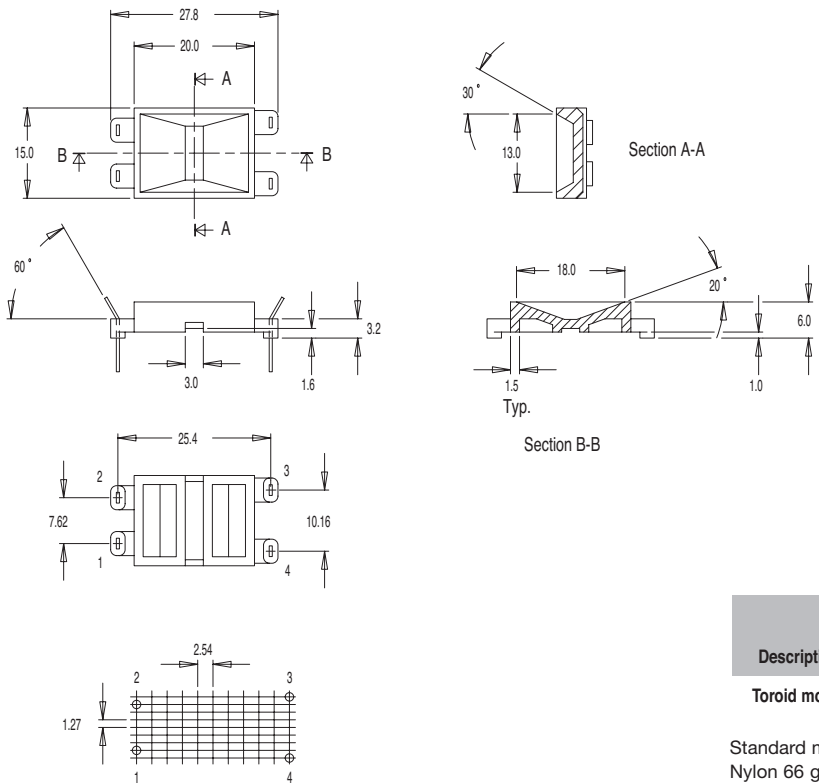

Description	Type	Terminal type	No. of terminals available	Part No.
Toroid mount	72959	TBS 901	4 (2 x 2)	TR0020

Standard materials: Nylon 66 glass reinforced to UL94HB / Nylon 66 glass reinforced to UL94V0  
Dimensions in millimetres



# Toroid Mounts

## TOROID MOUNT TR0030

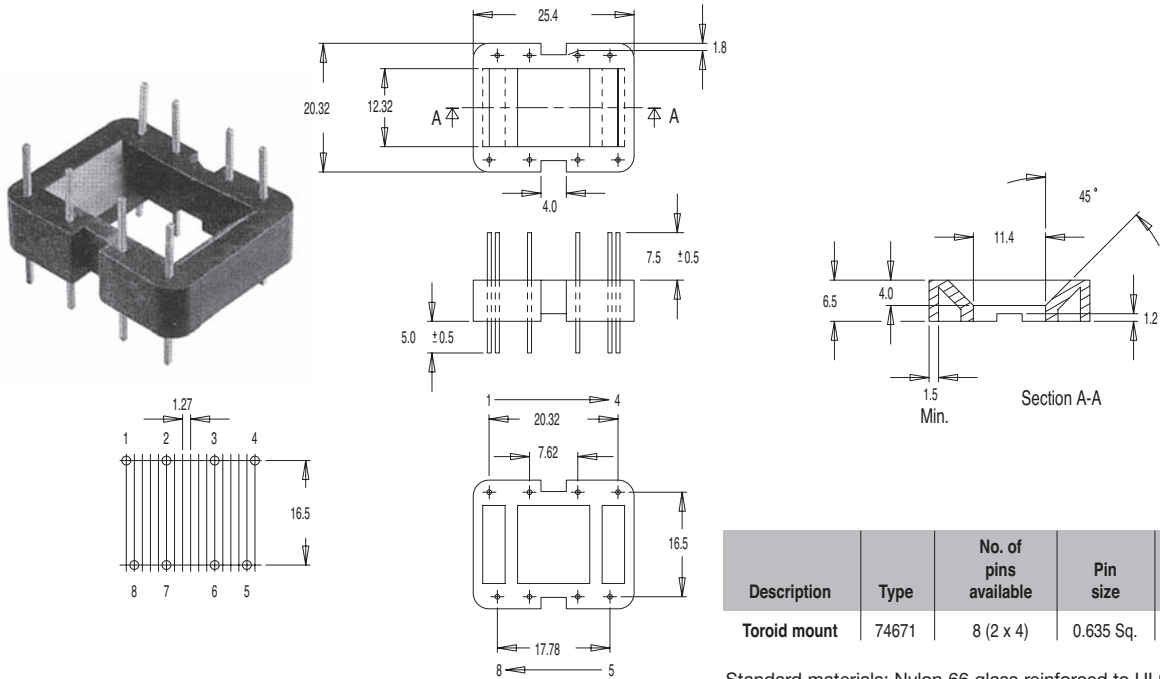

Standard materials: Nylon 66 glass reinforced to UL94HB / Nylon 66 glass reinforced to UL94V0  
 Pin material: Phosphor Bronze Dimensions in millimetres

## TOROID MOUNT TR0040

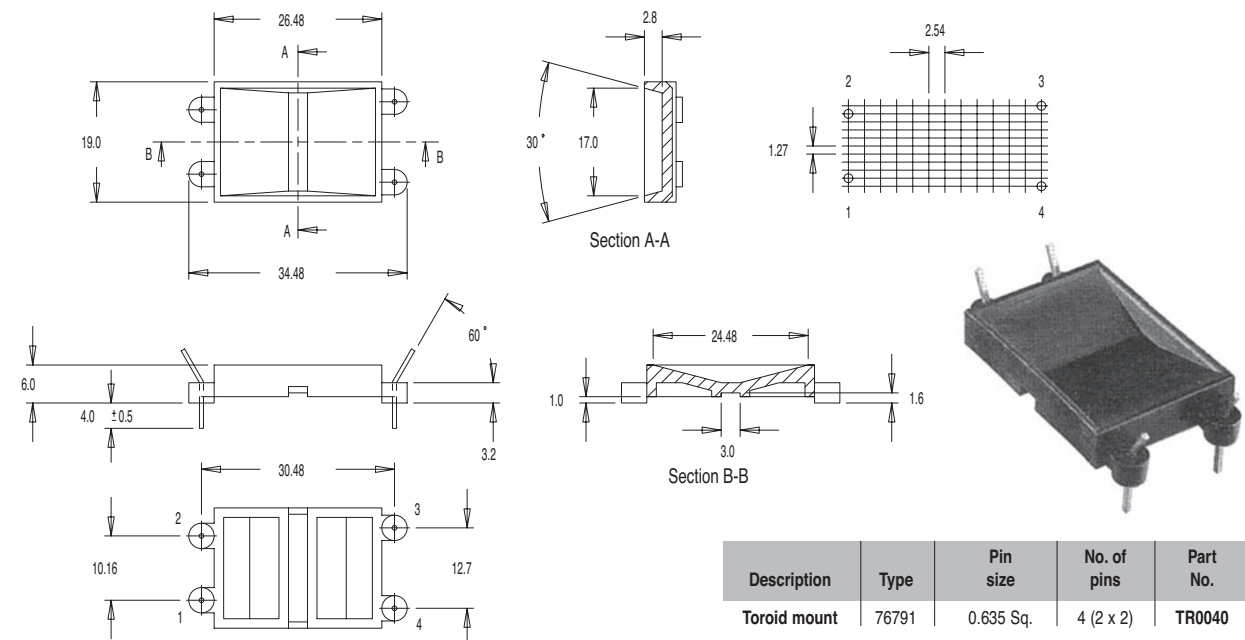

Standard materials: Nylon 66 glass reinforced to UL94HB / Nylon 66 glass reinforced to UL94V0  
 Pin material: Phosphor Bronze Dimensions in millimetres



# Toroid Mounts

## TOROID MOUNT TR0050

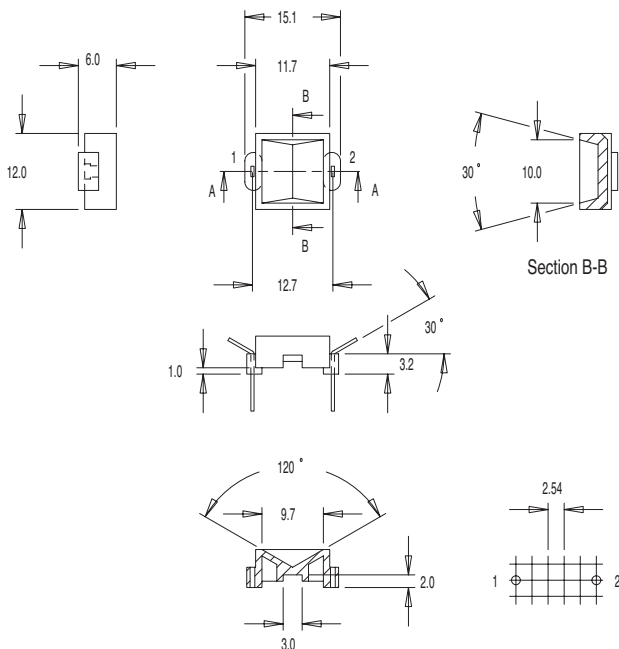
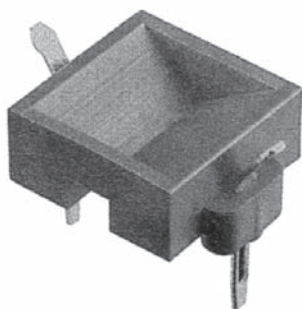

Description	Type	Terminal type	No. of terminals available	Part No.
Toroid mount	79796	TBS 901	2	TR0050

Standard materials: Nylon 66 glass reinforced to UL94HB /  
Nylon 66 glass reinforced to UL94V0 Dimensions in millimetres

## TOROID MOUNT TR0060

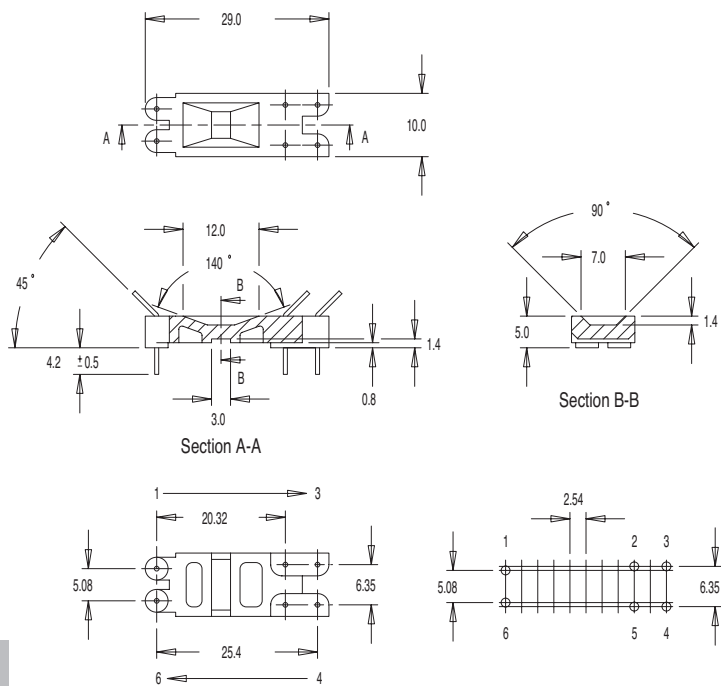
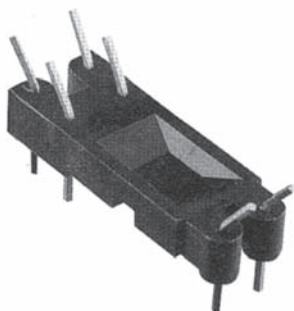

Description	Type	Pin size	No. of pins	Part No.
Toroid mount	76507	0.635 Sq.	6 (2 x 3)	TR0060

Standard materials: Nylon 66 glass reinforced to UL94HB /  
Nylon 66 glass reinforced to UL94V0 Dimensions in millimetres



# Toroid Mounts

## TOROID MOUNT TR0070

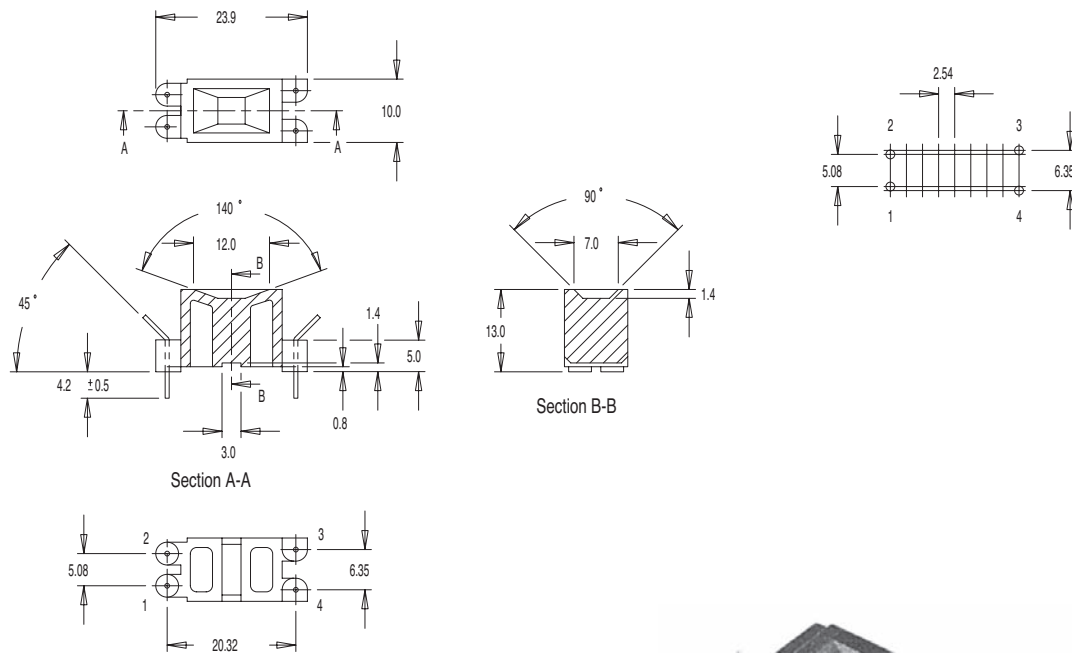

Description	Type	Pin size	No. of pins	Part No.
Toroid mount	77379	0.635 Sq.	4 (2 x 2)	TR0070

Standard materials: Nylon 66 glass reinforced to UL94HB / Nylon 66 glass reinforced to UL94V0  
 Pin material: Phosphor Bronze Dimensions in millimetres

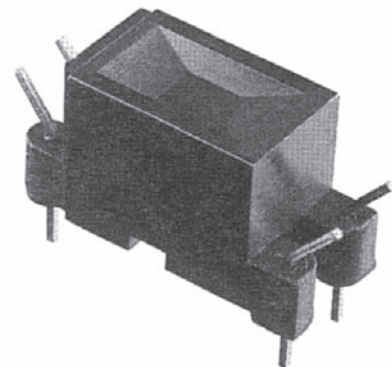



**MILES · PLATTS**

“ We develop product and processes through innovation and technology. ”

“ Wir entwickeln Erzeugnisse und Verfahren durch Innovation und Technologie. ”

“ Nous développons des produits et des procédés par l’innovation et la technologie. ”

“ Desarrollamos los productos y los procesos mediante la innovación y la tecnología. ”

